

Brake Caliper DU 060 FPM

spring activated – pneumatically released

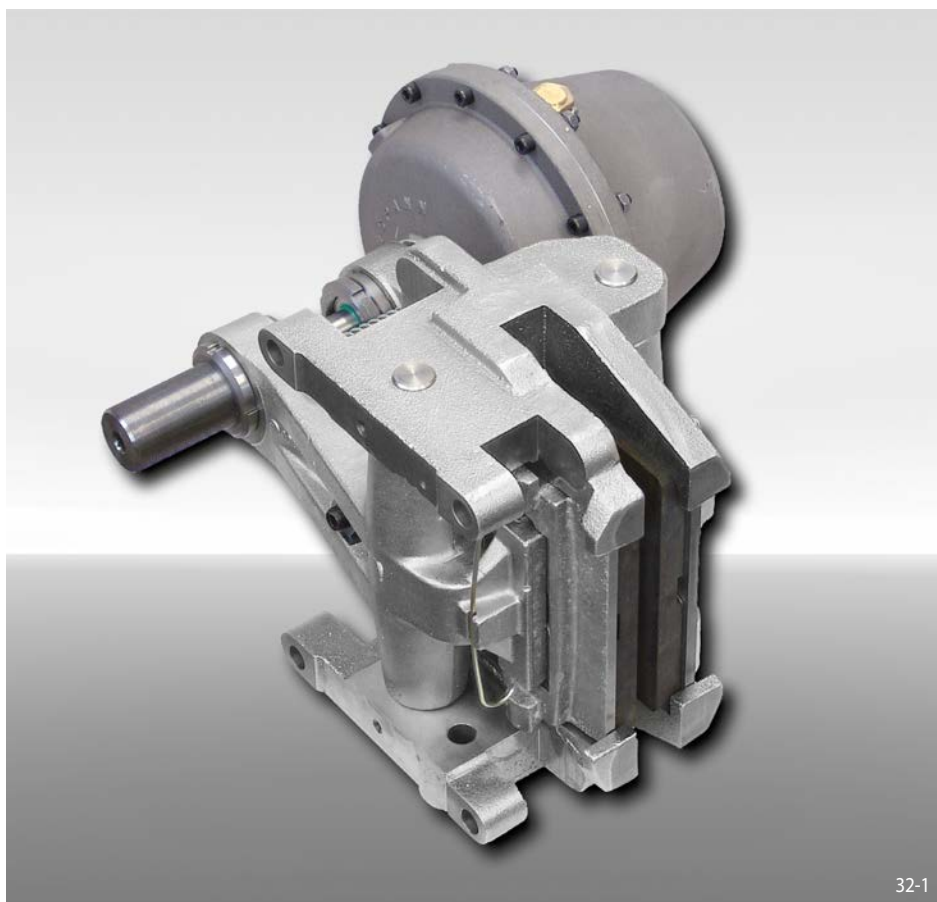

Features

Features	Code
Brake Caliper	D
Mounting to the machine, can be made either parallel or at the right angles to the brake disc	U
Frame size 060	060
Spring activated	F
Pneumatically released	P
Manual adjustment to accommodate friction block wear	M
Thrusters 111, 122, 130, 135, 140, 150, 155 or 160 are available	111 to 160
Thruster mounted right or left available	R L
Thickness of brake disc 25 mm or 40 mm	25 40

Example for ordering

Brake Caliper DU 060 FPM, thruster 130, thruster mounted right, thickness of brake disc 25 mm:

32-1

DU 060 FPM - 130 R - 25

Technical Data

	Brake Caliper DU 060 FPM							
	with thruster 111	with thruster 122	with thruster 130	with thruster 135	with thruster 140	with thruster 150	with thruster 155	with thruster 160
Brake disc diameter	Braking torque	Braking torque	Braking torque	Braking torque	Braking torque	Braking torque	Braking torque	Braking torque
mm	Nm	Nm	Nm	Nm	Nm	Nm	Nm	Nm
630	4900	6300	2700	5400	7800	7300	10300	13000
710	5600	7300	3100	6200	9000	8500	12000	15500
800	6500	8400	3600	7200	10300	9700	14000	17500
900	7400	9700	4100	8300	11900	11200	16000	20500
1000	8400	10900	4700	9300	13500	12500	18000	23000
1250	10700	14000	6000	12000	17000	16000	23000	29500
1600	14000	18500	7800	16000	22500	21000	30000	38500
Clamping force	24000 N	31000 N	13200 N	26500 N	38000 N	36000 N	51000 N	65000 N
Air pressure	min. 5 bar max. 8 bar	min. 6,5 bar max. 8 bar	min. 2,8 bar max. 8,5 bar	min. 5,5 bar max. 8,5 bar	min. 8,5 bar max. 10 bar	min. 4,5 bar max. 8,5 bar	min. 5,5 bar max. 8,5 bar	min. 7,6 bar max. 8,5 bar
Air volume per activation	max. 80 cm ³	max. 80 cm ³	max. 200 cm ³	max. 200 cm ³	max. 200 cm ³	max. 400 cm ³	max. 400 cm ³	max. 400 cm ³
Weight	60 kg	60 kg	62 kg	62 kg	62 kg	70 kg	70 kg	70 kg

The braking torques shown in the table are based on a theoretical friction coefficient of 0,4.

Brake Caliper DU 060 FPM

spring activated – pneumatically released

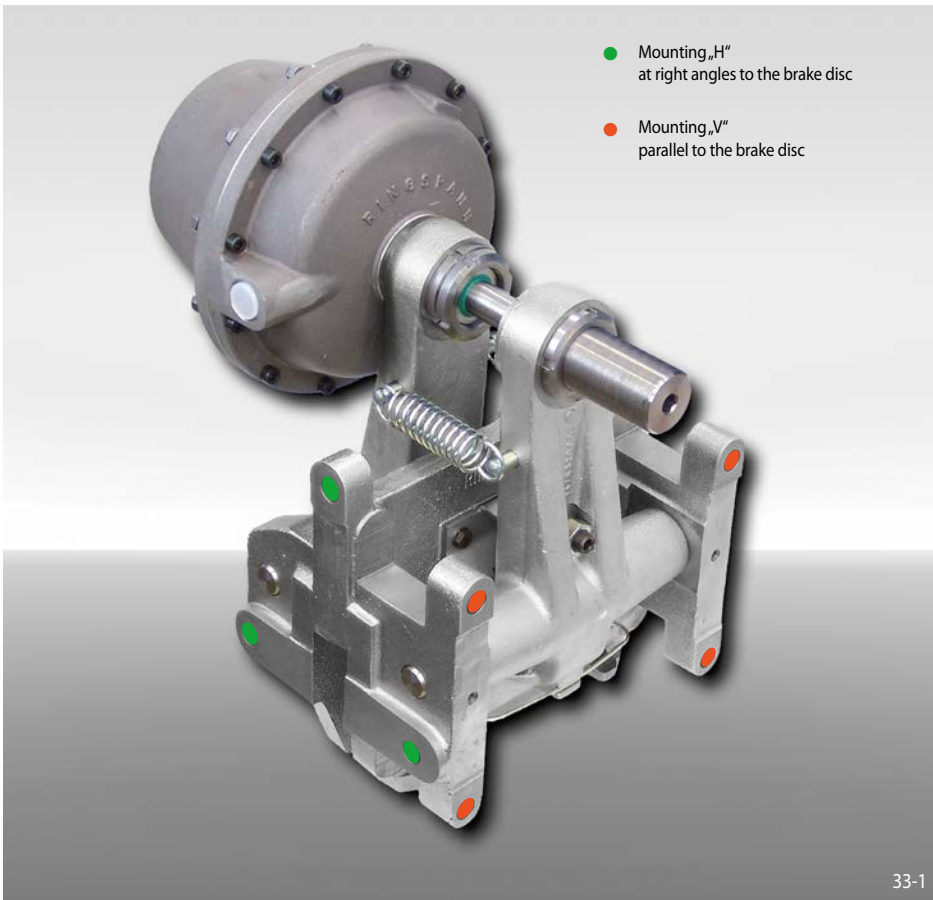

- Mounting „H“ at right angles to the brake disc
- Mounting „V“ parallel to the brake disc

Frame Design

